

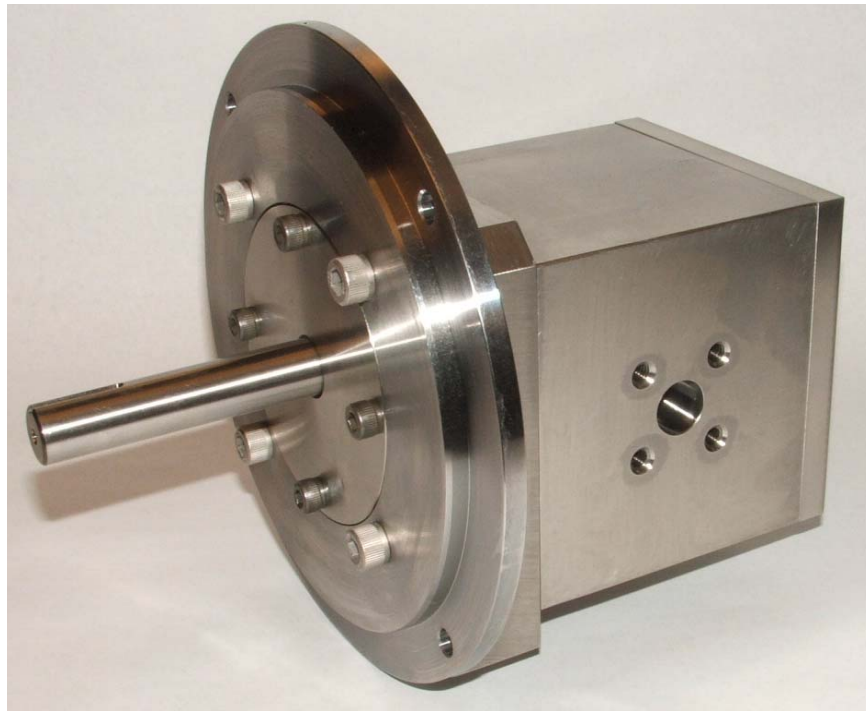

Maintenance Manual

Instructions for Disassembly, Cleaning, Inspection, and
Assembly of Northern® NPC Pumps

Models NPC-.5, NPC-1, and NPC-3



340 West Benson Avenue
Grantsburg, WI 54840
1-800-366-1410
715-463-5177

www.northern-pump.com



Table of Contents

Cautionary Statements	3
Removal from Installation	4
Outline Drawing	5
Figure 1	6
Figures 2 & 3	7
Figures 4 & 5	8
Disassembly	9
Clean-up	11
Inspection	12
Assembly	15
Installation	18
Parts List -- Model NPC-.5	19
Parts List -- Model NPC-1	20
Parts List -- Model NPC-3	21
Consumable Parts List	22
Recommended Spare Parts List -- Model NPC-.5	22
Recommended Spare Parts List -- Model NPC-1	23
Recommended Spare Parts List -- Model NPC-3	24
Trouble Shooting Guide	25
Lubrication and Preventative Maintenance	27

Cautionary Statements

Failure to heed these cautionary statements may result in personal injury and/or damage to equipment.

1. Disable and lock-out the drive system before any work is done to maintain or remove the pump.
2. Fully depressurize the entire system.
3. Close the valve closest to the pump in both the suction and discharge pipe.
4. Wear protective eyewear.
5. When handling corrosive, caustic, toxic, or hazardous liquids, wear protective clothing to prevent contact with skin.
6. Wear protective footwear such as safety shoes.
7. When handling liquids with toxic vapors, wear a properly rated breathing mask.
8. Work area must be properly ventilated.
9. Work area must be properly grounded.
10. Do not work alone.
11. Clean up any spilled liquid immediately.

Removal from Installation

1. Turn off and lock out the drive mechanism.
2. If the reservoir is pressurized, fully depressurize it.
3. Close the valve in the suction and discharge lines closest to the pump.
4. Place a pan or other liquid collecting device under the pump to collect the liquid that will drain from the pump and the suction and discharge lines when the suction and discharge lines are disconnected from the pump.
5. Disconnect the suction and discharge lines at the union or flange closest to the pump. Position the removed lines so that liquid is not spilled.
6. Remove the suction and discharge port adapters from the pump. Remove the adapter gaskets.
7. Remove the cap screws holding the pump's mounting flange in place. Hold the pump so that it does not fall from its mounting.
8. Remove the pump from its mounting by pulling it straight out. The shaft coupling is a jaw type coupling and should separate when the pump is pulled straight out.
9. Loosen the setscrew in the coupling hub on the pump's drive shaft and remove it. If it does not slide off easily, use a puller to remove it. Do not drive it off with a hammer or force it off with a pry bar.
10. Clean up any spilled liquid.
11. Recycle or dispose of spilled liquid as approved by owner's regulations.

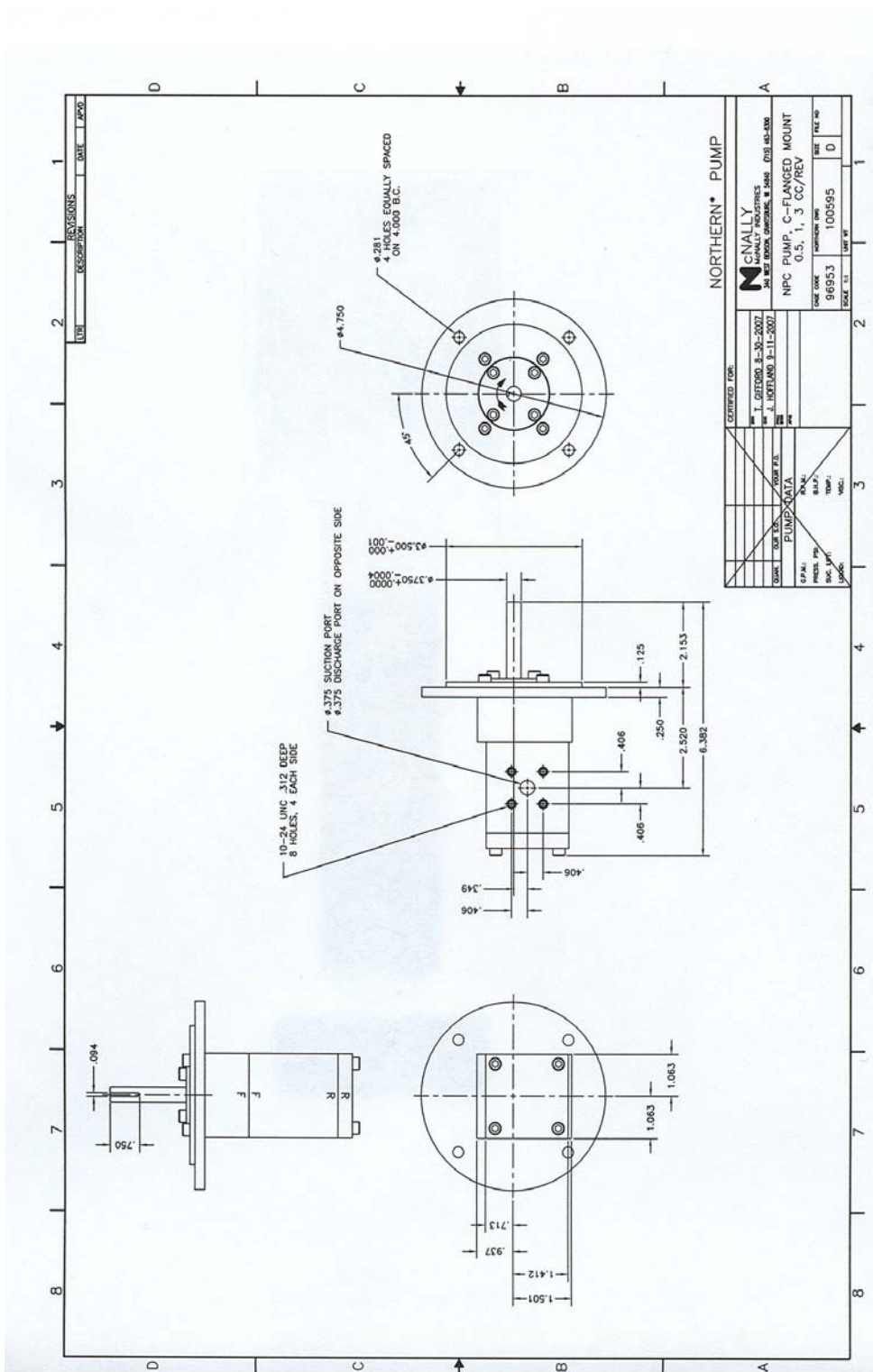

Outline Drawing

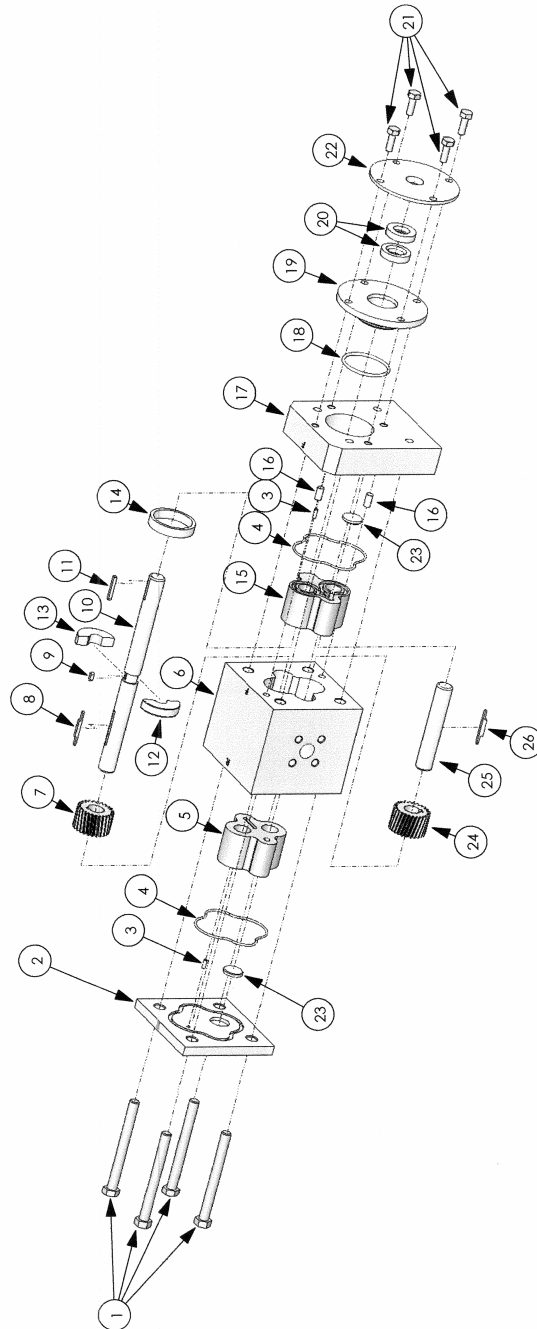
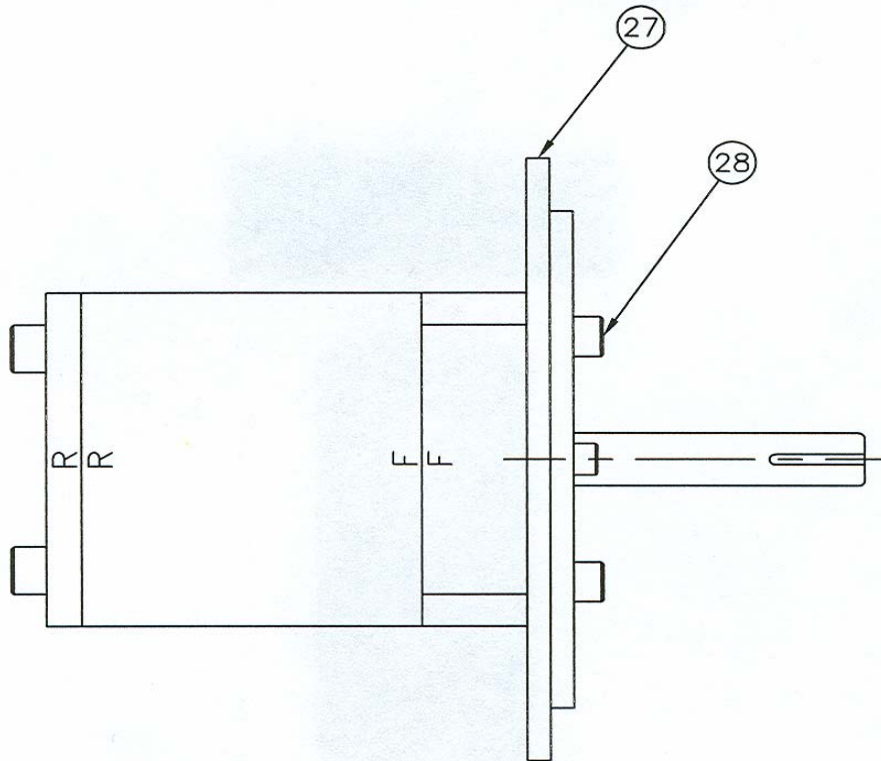

Figure 1



Top View of Pump
Figure 2

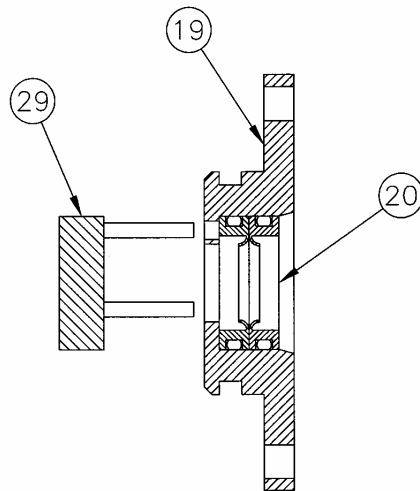
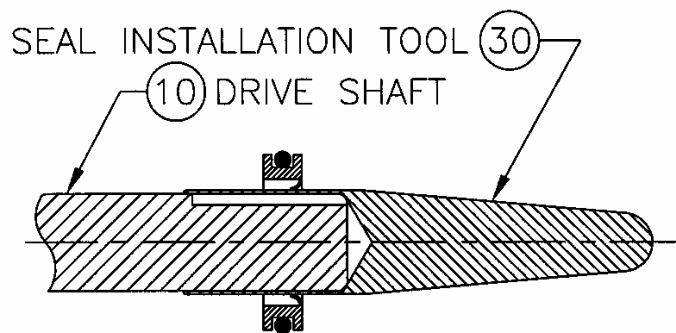

Figure 3

Figures 2 & 3



INBOARD SEAL, INSTALL FIRST

FIGURE 4

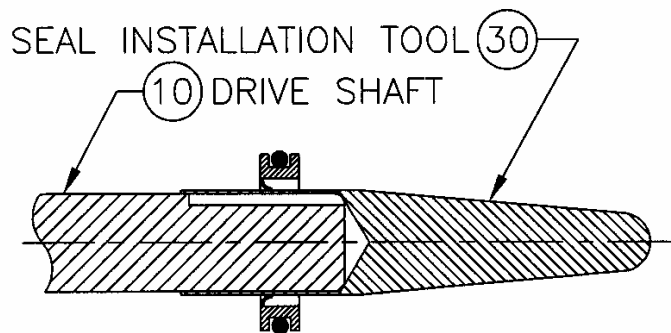

OUTBOARD SEAL, INSTALL LAST

FIGURE 5

Figures 4 & 5

Disassembly

1. Position pump so as to catch any liquid that may be released from the pump during disassembly.
2. Remove the key (11), Figure 1, from the drive shaft (10).
3. Check the drive shaft for burrs in the coupling area. Remove all burrs.
4. Remove cap screws (28), Figure 2, and remove the mounting flange (27), Figure 2.
5. Remove cap screws (1) and remove the rear end plate (2).
6. Dowel pin (3) will be found in either the rear end plate (2) or the rear bearing insert (5). Remove it.
7. Remove the O-ring (4) from the rear end plate.
8. Remove the cylinder (6) from the seal adapter plate (17). Leave the gears (7, 24), shafts (10, 25), and bearing inserts (5, 15) in place. Hint: Push in on the rear bearing insert (5) with your thumbs while pulling on the cylinder (6) to remove it. NOTE: In some applications, the nature of the pumped liquid is such that removal of the cylinder (6) is difficult. A tool is available to facilitate the removal of the cylinder (6).
9. Dowel pins (16) will be found in either the cylinder (6) or the seal adapter plate (17). Remove them.
10. Remove the rear bearing insert (5) from the two shafts (10, 25).
11. Remove the driven gear (24) and driven shaft (25) from the front bearing insert (15).
12. Remove the driven gear (24) from the driven shaft (25).
13. Remove the driven gear key (26) from the driven shaft (25).
14. Remove the drive gear (7) from the drive shaft (10).
15. Remove the drive gear key (8) from the drive shaft (10).

16. Remove the front bearing insert (15).
17. Dowel pin (3) will be found in either the seal adapter plate (17) or the front bearing insert (15). Remove it.
18. Remove O-ring (4) from the seal adapter plate (17).
19. Remove cap screws (21) and remove the seal retainer (22) from the seal housing (19).
20. Remove the seal housing (19) and drive shaft (10) from the seal adapter plate (17). Hint: Push on the gear end of drive shaft (10) with your thumb while holding seal adapter plate (17).
21. Remove the drive shaft (10) from the seal housing (19).
22. Remove O-ring (18) from the seal housing (19).
23. Remove the outer ring (14) from the thrust washer (12, 13) on the drive shaft (10).
24. Remove the two halves of the thrust washer (12, 13) from the drive shaft (10).
25. Remove the thrust washer drive key (9) from the drive shaft (10).
26. Press the drive shaft seals (20) from the seal housing (19) by inserting the pins of the seal removal tool (29) through the holes in end of the seal housing (19), Figure 3.
27. The rear end plate (2) and the seal adapter plate (17) each have a Teflon[®] thrust disk (23) pressed into a recess. Removing the thrust disk (23) will also destroy it. Remove it only if you are going to replace it. It can be removed by driving a small screwdriver or small punch into it and prying it out of the recess.



Clean-up

Clean all parts of the pump in accordance with the owner's cleaning procedures. Take all appropriate precautions to prevent damage to the parts of the pump during the cleaning process.

All parts of the pump may be heated to 200 °C (392 °F).

Inspection

1. Visually inspect all parts for obvious problems -- scratches on surfaces that mate with seals, cracks, upset metal that will affect how parts mate together, burrs, serious wear. Correct problem or replace part as necessary.
2. Inspect the front and rear bearing inserts for wear:
 - 2.1 Shaft bearing bores: .379 inch, maximum (9.63 mm, maximum)
 - 2.2 Thickness: The minimum allowable thickness where the gear contacts the surface of the bearing insert is:

NPC-.5	1.013 inch (25.73 mm)
NPC-1	.885 inch (22.48 mm)
NPC-3	.373 inch (9.47 mm)
 - 2.3 Visual: No nicks, burrs, scratches or other defects are allowable on the exterior surfaces that mate with the cylinder, rear end plate, or seal adapter plate. No scratches or grooves are allowed on the surface that mates with the meshing gears.
3. Inspect the drive shaft for wear:
 - 3.1 Keyways: No nicks or burrs are allowed on the edges of the keyways.
 - 3.2 Bearing areas: The minimum allowable diameter where the shaft contacts the bearing bore in the bearing insert is .374 inch (9.50 mm).
 - 3.3 Lip seal area: The minimum allowable diameter where the lip seals contact the shaft is .374 inch (9.50 mm). No scratches, pits, or other surface defects are allowed.
 - 3.4 Thrust washer area: No burrs or upset material is allowed on the shoulders that support the thrust washer.
 - 3.5 Coupling area: No burrs or upset material is allowed on the surface of the drive shaft that mates with the coupling.

4. Inspect the driven shaft for wear:

- 4.1 Keyway: No nicks or burrs are allowed on the edges of the keyway.
- 4.2 Bearing areas: The minimum allowable diameter where the shaft contacts the bearing bore in the bearing insert is .374 inch (9.50 mm),

5. Inspect the cylinder for wear:

- 5.1 End surfaces: No nicks, burrs, or scratches are allowed on the ends of the cylinder.
- 5.2 Gear bores: Visually inspect the gear bores for any sign that the gear has contacted the surface of the gear bore. No nicks, scratches, grooves, or galling is allowed on the gear bore surface. If any of these conditions exist, check the gear outer diameter, shaft bearing diameter, and bearing insert bearing bore diameter for wear and replace as necessary.

6. Inspect the gears:

- 6.1 End surfaces: Visually inspect the end surfaces of the gears. No nicks, scratches, grooves, or other defects are allowed.
- 6.2 Overall length: The minimum allowable length of the gear is:
NPC-.5 .255 inch (6.48 mm)
NPC-1 .511 inch (12.98 mm)
NPC-3 1.535 inch (38.99 mm)
- 6.3 Outside diameter: The minimum allowable outside diameter of the gear is .752 inch (19.10 mm). No nicks scratches, grooves or other defects are allowed.
- 6.4 Tooth surfaces: Visually inspect the gear tooth surfaces. No nicks, scratches, grooves, or other defects are allowed. Replace if necessary.



7. Inspect the thrust washer:

- 7.1 Visual: No nicks, scratches, burrs, grooves or other defects are allowed.
- 7.2 Thickness: The minimum allowable thickness is .360 inch (.91 mm).
- 7.3 Keyway: Visually inspect the keyway. No deformation of the keyway is allowed.

8. Inspect the shaft seals:

- 8.1 Visual: Inspect the edge of the lip for signs of wear, cuts, or tears. Replace if any defect is present.
- 8.2 Aging: Inspect the lip for flexibility. It must be firm and pliable. When deformed, the lip must return to its original shape.
- 8.3 O-ring: Visually inspect the O-ring. Cuts, scratches, tears, or permanent deformation of the O-ring is not allowed. Either replace the O-ring or replace the entire seal if any defect is present.

9. Inspect the O-rings:

- 9.1 Visual: No nicks, scratches, cuts, tears, or permanent deformation are allowed.
- 9.2 Aging: The O-ring must be firm and pliable. Replace if necessary.

Assembly

NOTE: All factory supplied fasteners are coated with a dry film lubricant. If fasteners are replaced with uncoated non-OEM fasteners, a suitable lubricant or anti-seize compound must be used.

1. Install the thrust washer drive key (9) into the drive shaft (10) keyway.
2. Assemble each half of the thrust washer (12, 13) on the drive shaft (10).
Note: Only one half of the thrust washer has a keyway.
3. Slide the thrust washer retaining ring (14) over the thrust washer (12, 13).
4. Install the O-ring (18) into the groove in the seal housing (19) pilot diameter.
5. Install the O-ring (4) into the groove in the seal adapter plate (17) and the rear end plate (2).
6. Install the drive shaft (10) and thrust washer (12, 13, 14) assembly into the seal adapter plate (17). The coupling end of the drive shaft (10) must be on the side of the adapter plate (17) where the seal housing (19) will be installed.
7. Install the seal housing (19) into the seal adapter plate (17). A light coat of lubricant on the O-ring will aid the installation of the seal housing (19). Temporarily secure with one cap screw (21), finger tight.
8. Install the bearing insert dowel pin (3) into the seal adapter plate (17).
9. Install the front bearing insert (15) over the drive shaft (10) until it engages the bearing insert dowel pin (3). Note: The front bearing insert has no groove on the side that fits against the end of the gears.
10. Install the drive gear key (8) into the drive shaft (10) keyway. Note: The keyway in the drive shaft (10) is not the same width as the keyway in the driven shaft (25). The drive shaft (10) has a narrower keyway than the keyway in the driven shaft (25).
11. Slide the drive gear (7) onto the drive shaft (10). Note: Each gear has different size keyway. Use the gear with the keyway that fits the key in the drive shaft (10).

12. Install the driven gear key (26) into driven shaft (25) keyway. Note: The keyway in the driven shaft (25) is wider than the keyway in the drive shaft (10).
13. Slide the driven gear (24) onto the driven shaft (25). Note: Each gear has a different size keyway. Use the gear with the keyway that fits the key in the driven shaft (25).
14. Install the driven shaft (25), driven gear (24), and driven gear key (26) assembly into the bearing bore in the front bearing insert (15).
15. Slide the rear bearing insert (5) over the drive shaft(10) and driven shaft (25). Note: The rear bearing insert has a relief groove on the side that fits against the end of the gears. This groove will be on the discharge side of the pump. The hole for the bearing insert dowel pin (3) will be next to the drive shaft (10).
16. Install the two dowel pins (16) into the seal adapter plate (17).
17. Carefully slide the cylinder (6) over the bearing inserts (5, 15) and engage the dowel pins (16) in the seal adapter plate (17). Note: The top of the seal adapter plate (17) has an "F" stamped into it. The top of the cylinder (6) has an "F" stamped into it. The cylinder (6) is correctly installed on to the seal adapter plate (17) when the two "F's" are adjacent to each other. See Figure 2.
18. Install the bearing insert dowel pin (3) into the rear end plate (2).
19. Install the rear end plate (2). Note: Orient the rear end plate (2) so that the bearing insert dowel pin (3) will properly engage the hole in the rear bearing insert (5).
20. Install cap screws (1) and tighten snugly. DO NOT OVER TIGHTEN.
21. The pump drive shaft (10) must rotate freely. If it does not, disassemble pump, determine the cause of the binding problem, correct it, and reassemble the pump.
22. Place the seal assembly tool over the drive shaft (see Figure 4). Slide the inner lip seal (20) over the drive shaft (10) and press it into the seal housing (19). A light coat of lubricant on the O-ring will aid the assembly of the lip seal (20) into the seal housing (19). The lip of this seal must be turned toward the pump body. See Figures 3 and 4.

23. Slide the outer lip seal (20) over the drive shaft (10) and press it into the seal housing (19). A light coat of lubricant on the O-ring will aid the assembly of the lip seal (20) into the seal housing (19). The lip of this seal must be turned away from the pump body. See Figures 3 and 5.
24. Remove the cap screw (21) that was temporarily installed in step 7.
25. Install the seal retainer plate (22) with the shouldered side toward the lip seals (20).
26. Install the cap screws (21) and tighten snugly. **DO NOT OVER TIGHTEN.**
27. Install the mounting flange (27), Figure 2. The mounting flange pilots over the OD of the seal housing (19). It must fit over the OD of seal housing (19) with .001 to .003 inch (.025 to .076 mm) clearance. If it does not, correct the problem, do not force the mounting flange over the seal housing (19) OD. Install cap screws (28), Figure 2, and tighten snugly. **DO NOT OVERTIGHTEN.**

Installation

1. Install the drive shaft end key (11) into the keyway.
2. Install the coupling hub on to the driveshaft. The coupling hub must slide freely on to the drive shaft. If it does not, locate the problem, correct it, and re-install the coupling hub. The coupling hub is normally positioned so that the end of the drive shaft is flush with the solid part of the coupling hub. Tighten the set screw over the drive shaft key snugly, **DO NOT OVERTIGHTEN.**
3. Install the pump on to the equipment mounting bracket. The drive shaft coupling hub must slide freely into its mating coupling hub. The pilot diameter on the pump mounting flange must engage the mounting bracket freely. Orient the pump so that the suction and discharge ports are properly aligned with the suction and discharge lines.
4. Install the four mounting bolts into the pump mounting flange and tighten snugly. **DO NOT OVERTIGHTEN.**
5. Check the coupling hubs to verify that they have the proper gap, usually .125 inch (3.2 mm). Correct if necessary. Verify that both coupling halves have properly tightened set screws.
6. Install the suction and discharge port adapters to the pump. A Teflon[®] gasket is used to seal each adapter to the pump body. **DO NOT OVERTIGHTEN THE CAP SCREWS.**
6. Connect the suction and discharge lines to the port adapters.
7. Open the suction and discharge valves.
8. Operate pump at moderate speed until pump has primed and air is purged from the pump.



Parts List

Model NPC-.5

Find No.	Nomenclature	Part Number	Qty
1	Cap Screw	100629	4
2	End Plate	100461	1
3	Bearing Insert Dowel Pin	100499	2
4	O-ring	19120128-90	2
5	Rear Bearing Insert	100496	1
6	Cylinder	100460	1
7	Drive Gear, LH	100494	1
8	Drive Gear Key	100503	1
9	Thrust Washer Key	100505	1
10	Drive Shaft	100446	1
11	Drive Shaft End Key	100500	1
12/13	Thrust Washer Set	100477	1
14	Thrust Washer Retaining Ring	100479	1
15	Front Bearing Insert	100495	1
16	Dowel Pin	100498	2
17	Seal Adapter Plate	100482	1
18	O-ring	19120119-90	1
19	Seal Housing	100467	1
20	Lip Seal	100501	2
21	Cap Screw	100630	4
22	Seal Retainer	100468	1
23	Thrust Disk	100506	2
24	Driven Gear, RH	100493	1
25	Driven Shaft	100447	1
26	Driven Shaft Gear Key	100504	1
27	Mounting Flange	100532	1
28	Cap Screw	100630	4
29	Seal Removal Tool	100518	1
30	Seal Installation Tool	100535	1



Parts List

Model NPC-1

Find No.	Nomenclature	Part Number	Qty
1	Cap Screw	100629	4
2	End Plate	100461	1
3	Bearing Insert Dowel Pin	100499	2
4	O-ring	19120128-90	2
5	Rear Bearing Insert	100451	1
6	Cylinder	100460	1
7	Drive Gear, LH	100437	1
8	Drive Gear Key	100497	1
9	Thrust Washer Key	100505	1
10	Drive Shaft	100446	1
11	Drive Shaft End Key	100500	1
12/13	Thrust Washer Set	100477	1
14	Thrust Washer Retaining Ring	100479	1
15	Front Bearing Insert	100450	1
16	Dowel Pin	100498	2
17	Seal Adapter Plate	100482	1
18	O-ring	19120119-90	1
19	Seal Housing	100467	1
20	Lip Seal	100501	2
21	Cap Screw	100630	4
22	Seal Retainer	100468	1
23	Thrust Disk	100506	2
24	Driven Gear, RH	100436	1
25	Driven Shaft	100447	1
26	Driven Shaft Gear Key	100487	1
27	Mounting Flange	100532	1
28	Cap Screw	100630	4
29	Seal Removal Tool	100518	1
30	Seal Installation Tool	100535	1



Parts List

Model NPC-3

Find No.	Nomenclature	Part Number	Qty
1	Cap Screw	100629	4
2	End Plate	100461	1
3	Bearing Insert Dowel Pin	100499	2
4	O-ring	19120128-90	2
5	Rear Bearing Insert	100453	1
6	Cylinder	100460	1
7	Drive Gear, LH	100439	1
8	Drive Gear Key	100497	1
9	Thrust Washer Key	100505	1
10	Drive Shaft	100446	1
11	Drive Shaft End Key	100500	1
12/13	Thrust Washer Set	100477	1
14	Thrust Washer Retaining Ring	100479	1
15	Front Bearing Insert	100452	1
16	Dowel Pin	100498	2
17	Seal Adapter Plate	100482	1
18	O-ring	19120119-90	1
19	Seal Housing	100467	1
20	Lip Seal	100501	2
21	Cap Screw	100630	4
22	Seal Retainer	100468	1
23	Thrust Disk	100506	2
24	Driven Gear, RH	100438	1
25	Driven Shaft	100447	1
26	Driven Shaft Gear Key	100487	1
27	Mounting Flange	100532	1
28	Cap Screw	100630	4
29	Seal Removal Tool	100518	1
30	Seal Installation Tool	100535	1



Consumable Parts List

Find No.	Nomenclature	Part Number	Qty
4	O-ring	19120128-90	2
18	O-ring	19120119-90	1
20	Lip Seal	100501	2

Recommended Spare Parts List

Model NPC-.5

Find No.	Nomenclature	Part Number	Qty
3	Bearing Insert Dowel Pin	100499	2
4	O-ring	19120128-90	2
5	Rear Bearing Insert	100496	1
6	Cylinder	100460	1
7	Drive Gear, LH	100494	1
8	Drive Gear Key	100503	1
9	Thrust Washer Key	100505	1
10	Drive Shaft	100446	1
11	Drive Shaft End Key	100500	1
12/13	Thrust Washer Set	100477	1
14	Thrust Washer Retaining Ring	100479	1
15	Front Bearing Insert	100495	1
18	O-ring	19120119-90	1
20	Lip Seal	100501	2
23	Thrust Disk	100506	2
24	Driven Gear, RH	100493	1
25	Driven Shaft	100447	1
26	Driven Shaft Gear Key	100504	1



Recommended Spare Parts List

Model NPC-1

Find No.	Nomenclature	Part Number	Qty
3	Bearing Insert Dowel Pin	100499	2
4	O-ring	19120128-90	2
5	Rear Bearing Insert	100451	1
6	Cylinder	100460	1
7	Drive Gear, LH	100437	1
8	Drive Gear Key	100497	1
9	Thrust Washer Key	100505	1
10	Drive Shaft	100446	1
11	Drive Shaft End Key	100500	1
12/13	Thrust Washer Set	100477	1
14	Thrust Washer Retaining Ring	100479	1
15	Front Bearing Insert	100450	1
18	O-ring	19120119-90	1
20	Lip Seal	100501	2
23	Thrust Disk	100506	2
24	Driven Gear, RH	100436	1
25	Driven Shaft	100447	1
26	Driven Shaft Gear Key	100487	1



Recommended Spare Parts List

Model NPC-3

Find No.	Nomenclature	Part Number	Qty
3	Bearing Insert Dowel Pin	100499	2
4	O-ring	19120128-90	2
5	Rear Bearing Insert	100453	1
6	Cylinder	100460	1
7	Drive Gear, LH	100439	1
8	Drive Gear Key	100497	1
9	Thrust Washer Key	100505	1
10	Drive Shaft	100446	1
11	Drive Shaft End Key	100500	1
12/13	Thrust Washer Set	100477	1
14	Thrust Washer Retaining Ring	100479	1
15	Front Bearing Insert	100452	1
18	O-ring	19120119-90	1
20	Lip Seal	100501	2
23	Thrust Disk	100506	2
24	Driven Gear, RH	100438	1
25	Driven Shaft	100447	1
26	Driven Shaft Gear Key	100487	1



Trouble Shooting Guide

Problem	Solution
Pump will not fit on mounting bracket	Check for burrs and nicks around the mounting bracket bore and the pilot diameter on the pump mounting flange. Remove as required.
Key will not fit into keyway in drive shaft	Check for burrs and nicks in the keyway and on the key. Remove as required. Measure width of key and keyway, if an interference fit is found, reduce the width of the key.
Motor shaft turns but pump shaft does not	Verify that the coupling has been properly installed with the correct key in each hub, the correct insert spider, and that the gap in the coupling hubs are properly engaged.
Pump will not prime	Check for air leaks in the suction line. Check for correct rotation of the pump shaft -- CW when facing the shaft end of the pump. "Wet" the internals of the pump with the liquid to be pumped to provide a liquid seal in the pumping chamber. Make sure that all suction and discharge line valves are open. Make sure that the suction and discharge lines are free of obstructions.



Problem	Solution
Pump requires too much torque	Make sure that the viscosity of the liquid being pumped is not abnormally high. Check for binding of the pump shaft
Pumped liquid has entrained air	Check for air leaks in suction line. Check for air leaks in the shaft seal.
Flow rate is too low	Make sure that the viscosity of the liquid being pumped is not abnormally low. Make sure that the discharge pressure is not abnormally high. Make sure that there are no air leaks in the suction line. Verify that the rotational speed is correct. Disassemble pump and verify that the internal clearances are within specification.

Lubrication and Preventative Maintenance

The pump is fully lubricated by the pumped liquid. It is capable of being run dry for short periods. However, dry running for extended periods must be avoided.

It is recommended that a very small amount of a liquid compatible with the liquid to be pumped be put into the pump at startup. This will lubricate the pump during the startup period and make the pump much easier to prime.

There is no preventative maintenance routine to follow for this pump as there are no manual adjustments or other actions required for normal operation.

It is required that the coupling be a slip fit on the pump shaft. Do not force the coupling and shaft together.

When attaching the suction and discharge lines to the pump adapters, make sure that the attached lines mate with the pump adapters naturally without being forced into position. Do not expect the pump to accept significant forces from the attached suction and discharge lines.