



The Northern Advantage



EXPERIENCE

RELIABILITY

SAFETY



Northern Gear Pumps

Manufacturing and design of custom pumps in industry leading delivery times...

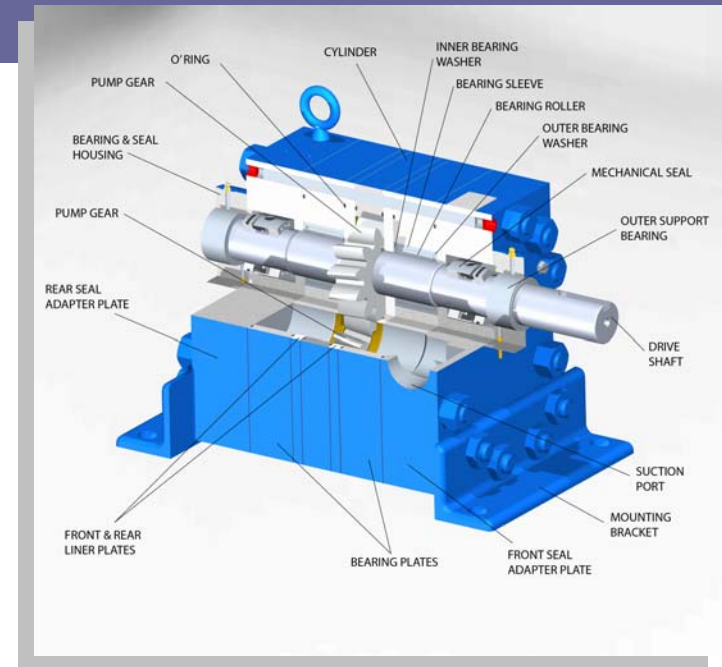

- Specialization
- Customization
- Precision Manufacturing
- Application Review
- Performance Testing
- Project Management
- Made in the U.S.A.

EXPERIENCE

RELIABILITY

SAFETY



Advantage #1

Specialization

- ✓ Northern ***ONLY*** Designs and Manufacturers Positive Displacement Gear Pumps.
- ✓ Northern Employs an Expert Team - Gear Pump Authorities
 - Hydraulic Principals
 - Material Options
 - Pump Testing
- ✓ Excellent Customer Service Leaders in Market Niche

EXPERIENCE

RELIABILITY

SAFETY



Advantage #2

Customization

- ✓ Pumps Available in All Shapes and Sizes
- ✓ Modular Pump Design = Customization for Each Application
- ✓ In House Engineers Monitor
 - Design
 - Manufacturing
 - Testing

EXPERIENCE

RELIABILITY

SAFETY



Advantage #3

Precision Manufacturing

- ✓ Northern's Core Competency is Manufacturing
- ✓ Precision Machine Shop Capable of Close Tolerances
- ✓ Parent Company – McNally Industries, LLC
 - Manufacture Complex Electro Mechanical Assemblies for DoD
 - Northern Embedded in McNally Manufacturing Facility
 - Wide Range of Manufacturing Capabilities

EXPERIENCE

RELIABILITY

SAFETY



Advantage #4

Application Review

- ✓ Our Reputation is Everything
- ✓ Each Application Carefully Reviewed
- ✓ Quality is Never Compromised

EXPERIENCE

RELIABILITY

SAFETY



Advantage #5

Performance Testing

- ✓ Every Pump Assembly Tested to Exact Duty Conditions
- ✓ Shipped Pumps are Guaranteed to Run as Designed on Site
- ✓ High Level of Confidence in Northern Pumps
 - Highly Trained Technicians Verify Performance
 - High Level of Quality Control

EXPERIENCE

RELIABILITY

SAFETY



Advantage #6

Project Management

- ✓ **Wisconsin Based Team Responsible for All Aspects of Manufacturing Process**
 - In House Design
 - Build the Data Package
 - Manufacture the Parts
 - Assembly
 - Testing
 - Development of Product Literature

EXPERIENCE

RELIABILITY

SAFETY



Advantage #7

Made in the U.S.A.

- ✓ Manufacture Most Components in WI Facility
- ✓ NO Cheap Cast Components from Overseas
- ✓ Complete Control Over Manufacturing Process
 - Design
 - Manufacturing
 - Testing
- ✓ High Level of Quality Control = High Quality Product and Shorter Lead Times

EXPERIENCE

RELIABILITY

SAFETY