

Cylinder Detail

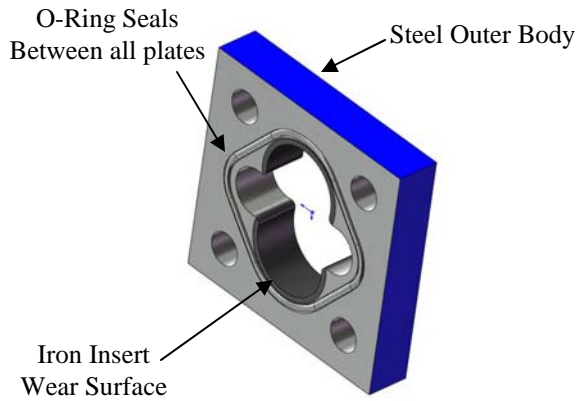

NORTHERN HIGH PRESSURE PUMP DESIGN DETAILS

- Up to 1200 PSI Inlet Pressure
- .5 to 150 GPM
- Up to 2000 PSI Discharge Pressure
- Temperatures to 850 F
- RPM up to 3600
- Various Materials Available

N Northern® Pump
Division of McNally Industries LLC
340 W. Benson Rd.
Grantsburg, WI 54840
(800) 366-1410
www.northern-pump.com

